

GCSE (9–1) Physics A (Gateway Science)

H

J249/03 Paper 3 (Higher Tier)

Sample Question Paper

Date – Morning/Afternoon

Version 2.1

Time allowed: 1 hour 45 minutes



You must have:

- the Data Sheet

You may use:

- a scientific or graphical calculator
- a ruler



First name										
Last name										
Centre number						Candidate number				

INSTRUCTIONS

- Use black ink. HB pencil may be used for graphs and diagrams only.
- Complete the boxes above with your name, centre number and candidate number.
- Answer **all** the questions.
- Write your answer to each question in the space provided.
- Additional paper may be used if required but you must clearly show your candidate number, centre number and question number(s).
- Do not write in the bar codes.

INFORMATION

- The total mark for this paper is **90**.
- The marks for each question are shown in brackets [].
- Quality of extended responses will be assessed in questions marked with an asterisk (*).
- This document consists of **28** pages.

SECTION A

Answer **all** the questions.

You should spend a maximum of 30 minutes on this section.

1 Look at the circuit diagram.

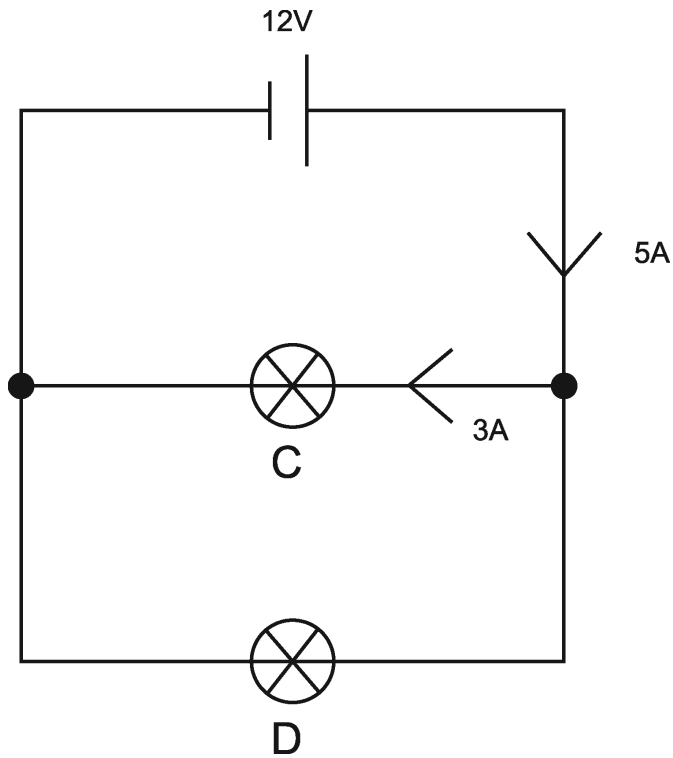

- resistance = potential difference \div current

Calculate the resistance of bulb **D**.

- A** 2 Ω
- B** 4 Ω
- C** 6 Ω
- D** 8 Ω

Your answer

[1]

- 2 The diagram shows a wire carrying an electric current.



Which diagram shows the magnetic field viewed from above, with the current coming towards you?

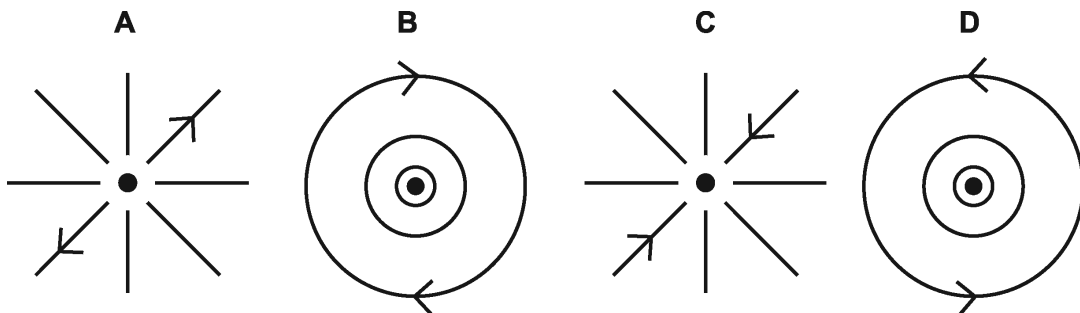

Your answer

[1]

- 3 Which of the following is **not** needed to generate a.c. in an alternator?

- A Changing magnetic field
- B Coil of wire
- C Commutator segment
- D Rotating magnet

Your answer

[1]

- 4 A student measures the magnetic flux density around a current carrying conductor at increasing distances from the conductor.

She plots her results.

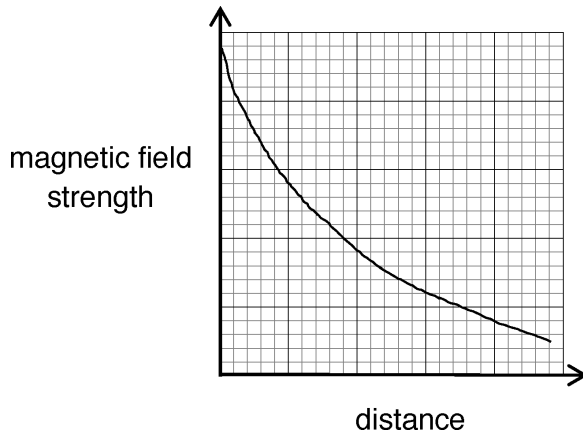

The current in the conductor is decreased and a new graph plotted.

Which is the correct graph?

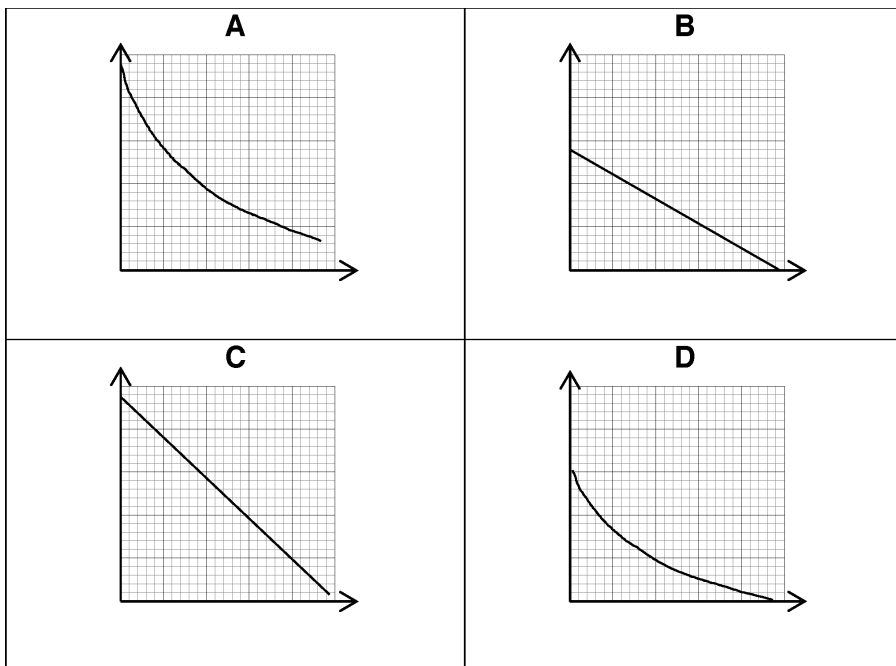

Your answer

[1]

5 A car travels 200 km in four hours.

The car **doubles** its speed.

How long would it take for the car to travel 50 km?

A 0.5 hours

B 1.0 hours

C 2.0 hours

D 4.0 hours

Your answer

[1]

6 A graduated syringe contains air at room temperature.

The syringe is put in a freezer to cool it down.

When it is removed from the freezer, the piston has moved inwards.

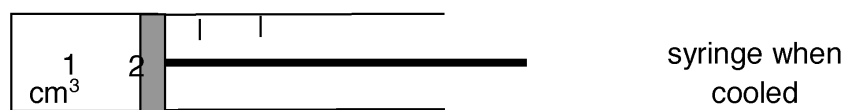
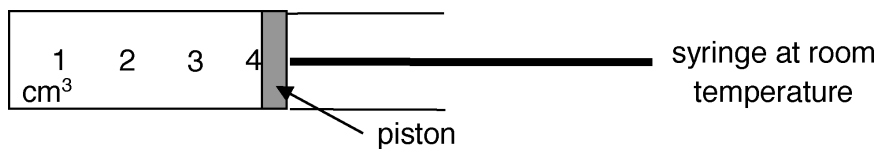

The density of the air in the syringe when cooled is 2.4 kg/m^3 .

What was the density of the air at room temperature?

A 0.6 kg/m^3

B 1.2 kg/m^3

C 2.4 kg/m^3

D 4.8 kg/m^3

Your answer

[1]

7 Three forces, x , y and z act on a body.

The body is in **equilibrium**.

Which vector diagram shows the body in equilibrium?

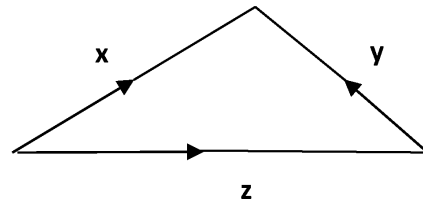
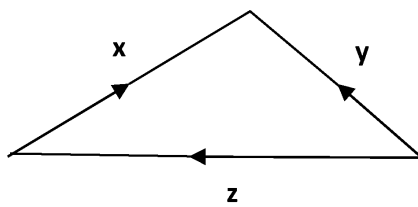
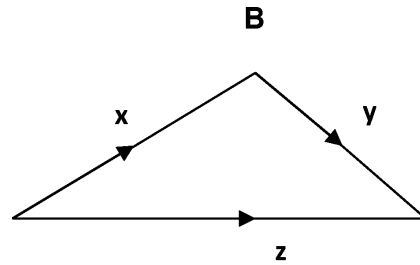
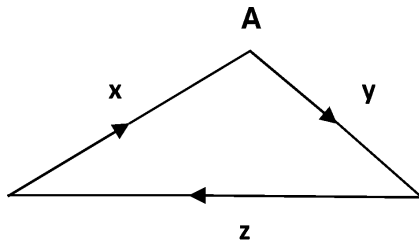

C

D

Your answer

[1]

- 8 A uniform 1.0 m rod is pivoted at its centre.

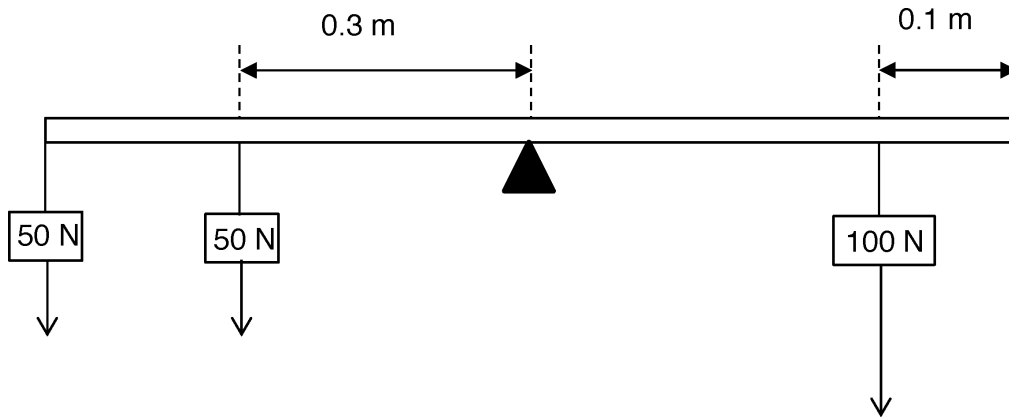

The rod is in equilibrium.

What is the anti-clockwise moment about the pivot?

- A 10 N m
- B 15 N m
- C 40 N m
- D 100 N m

Your answer

[1]

9

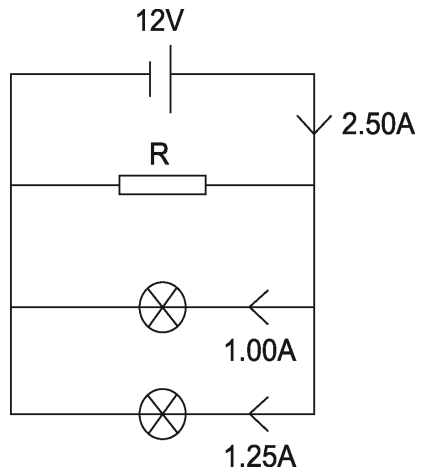

Calculate the power dissipated by resistor **R**.

- A** 3 W
- B** 12 W
- C** 15 W
- D** 30 W

Your answer

[1]

10

The diagram shows two poles of a magnet.

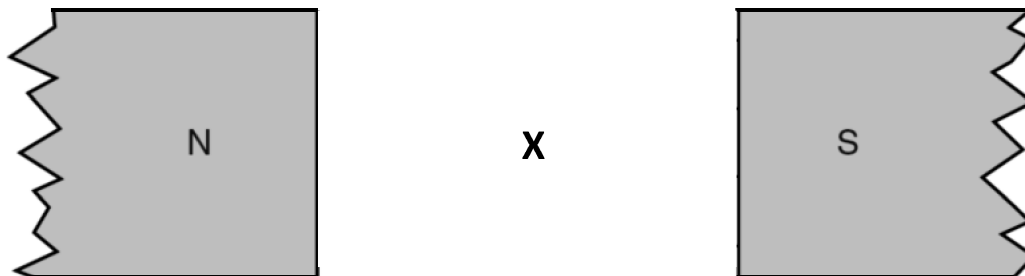

X is the position of a wire carrying a current perpendicularly into the paper.

Which direction does the wire move?

- A** ↓
- B** →
- C** ←
- D** ↑

Your answer

[1]

11 A piece of metal has a volume of $2.0 \times 10^{-5} \text{ m}^3$.

The density of the metal is $8.0 \times 10^3 \text{ kg/m}^3$.

What is the mass of the metal?

A $2.5 \times 10^{-3} \text{ kg}$

B $4.0 \times 10^{-2} \text{ kg}$

C $1.6 \times 10^{-1} \text{ kg}$

D $1.6 \times 10^3 \text{ kg}$

Your answer

[1]

12 The diagram shows 3 gears.

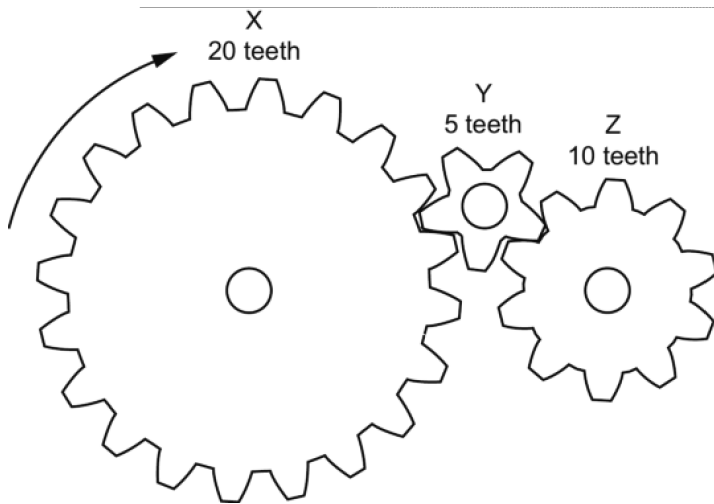

Gear X is rotated clockwise at 1.0 rotations per second.

Which row describes the movement of gear Z?

	Direction of rotation	Rotations per second
A	anticlockwise	0.5
B	anticlockwise	2.0
C	clockwise	0.5
D	clockwise	2.0

Your answer

[1]

- 13** A car and driver with a total mass of 1 000 kg is travelling at 20 m/s.
The driver applies the brake and the car comes to a stop in 4 seconds.
What is the mean force on the car?

- A** 12.5 N
- B** 200 N
- C** 5 000 N
- D** 80 000 N

Your answer

[1]

- 14** The current in a 12 Ω resistor is 9.0 A.
How much power is dissipated?

- A** 108 W
- B** 972 W
- C** 1 296 W
- D** 11 664 W

Your answer

[1]

- 15** A spring, of spring constant 16 N/m, is stretched by 50 cm.
What is the work done?

- A** 2.0 J
- B** 8.0 J
- C** 12.5 J
- D** 25.0 J

Your answer

[1]

11
BLANK PAGE

TURN OVER FOR THE NEXT QUESTION

SECTION B

Answer **all** the questions.

- 16** A student does an experiment to find the specific heat capacity of a metal block.

The diagram shows the apparatus used.

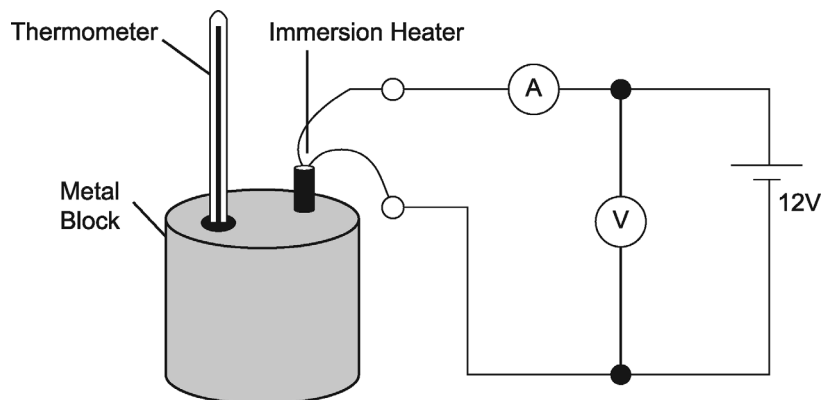

- (a) (i)** The student measures the voltage and current.

Suggest **three** other measurements he needs to take?

.....

.....

..... **[3]**

- (ii)** Describe how these measurements could be used to find the specific heat capacity of the metal.

.....

.....

..... **[2]**

(b) The specific heat capacity obtained from the experiment is much larger than expected.

- Suggest **two** reasons for this difference.
- Suggest **two** improvements to the method that might give a more accurate value for the specific heat capacity.

.....

.....

.....

.....

.....

.....

[4]

(b) Current is the rate of flow of electrical charge in a circuit.

A current of 40 mA transfers a charge of 3.6 C.

Calculate the time to transfer this charge.

Show your working.

.....

.....

.....

Answer = seconds **[3]**

- 18 (a) A depth of 10 m of water exerts the same amount of pressure as the entire Earth's atmosphere, which is ~120 km deep.

Suggest why.

..... [1]

- (b) A diver takes pressure readings at different depths.

The results are in the table.

Depth of water (m)	Pressure (standard units)
0	1
10	2
20	3
30	4
40	5
50	6

Use the results to describe the relationship between the depth of water and pressure.

.....
.....
..... [2]

- (c) Suggest why there is pressure at 0 metres.

.....
..... [1]

(d) A container of vegetable oil has 3 holes in it (**A**, **B** and **C**).

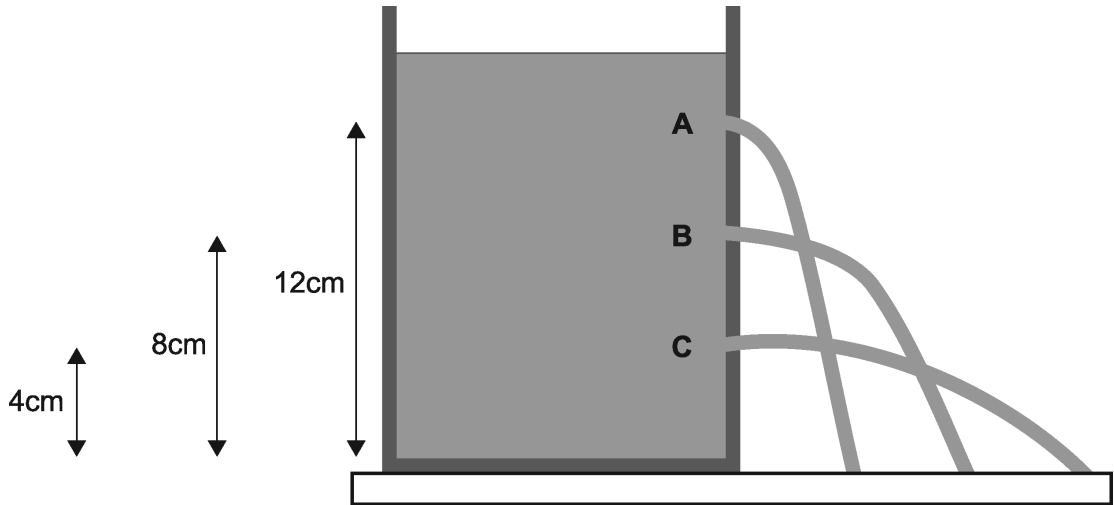

The vegetable oil has a density of $9.1 \times 10^2 \text{ kg/m}^3$.

Calculate the change in pressure from **A** to **B**.

Show your working and give your answer to **two** significant figures.

.....

.....

.....

.....

.....

Answer = Pa [4]

- 19** A student takes voltage and current measurements for four resistors (A, B, C and D).

The table shows the results from this experiment.

Resistor	Voltage (V)	Current (A)	Resistance (Ω)
A	12.0	2.0	
B	6.0	1.5	
C	7.5	1.5	
D	8.0	2.0	

- (a) Which two resistors have the same resistance value?

Use the results to show this.

.....

 [2]

- (b) Calculate the maximum resistance that can be made using all four resistors.

.....

 Answer = Ω [1]

- (c) (i) Draw a circuit diagram that could be used to find out how the resistance of a filament bulb changes with current.

Describe the readings you need to take.

.....

 [4]

(ii) Sketch the shape of the graph from (c)(i) using the axes below.

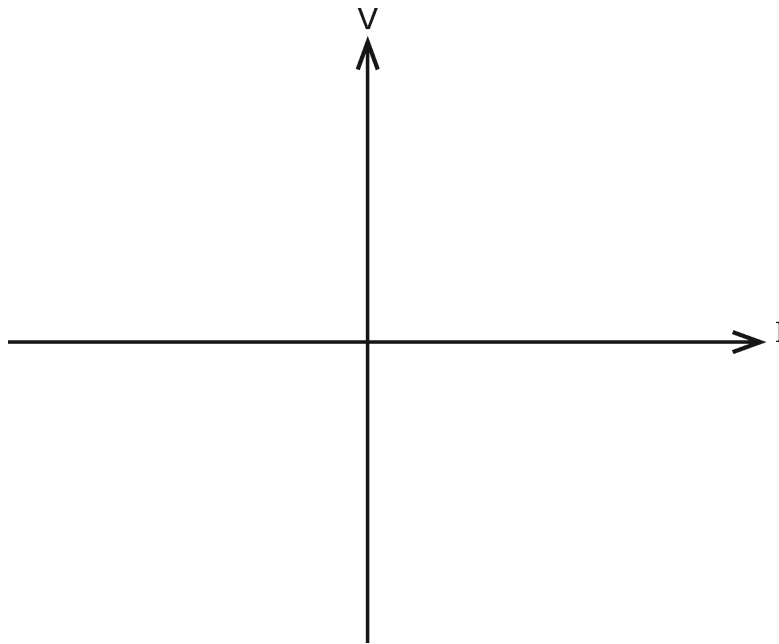

State how this graph can be used to calculate resistance at any specific value of current.

.....
 [2]

(d) A voltmeter is used to measure the output voltages produced from the circuit.

The voltmeter is **not** connected to a circuit and **not** recording a voltage.

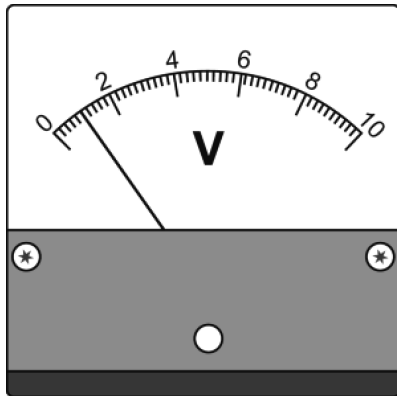

Name the type of error on the voltmeter and suggest how it should be dealt with.

.....
 [2]

20 A student investigates the motion of a glider on a frictionless air track using the apparatus shown below.

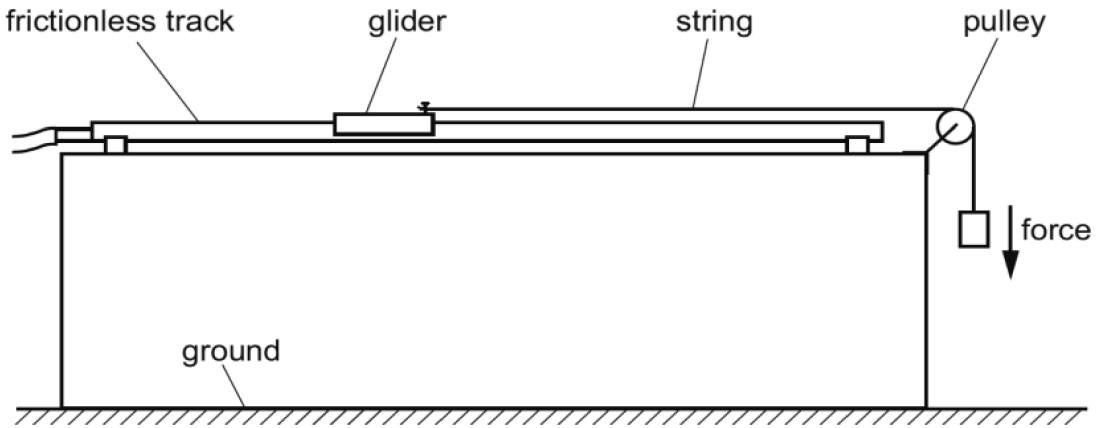

(a) (i) Explain how the student can use this apparatus to demonstrate Newton's Second Law.

Include details of any additional equipment required.

.....
.....
.....
.....
.....
.....
..... [3]

(ii) A 0.25 kg glider is pulled by a 1.0 N force.

Calculate the acceleration of the glider using the formula:

$$\text{force} = \text{mass} \times \text{acceleration}$$

.....
.....
.....
.....

Answer = m/s² [1]

(iii) Suggest reasons why the recorded value was less than your calculated value.

.....
 [2]

(b) The student repeats the experiment for 4 more forces.

The results are shown in the table.

Force (N)	Acceleration (m/s ²)			
	Attempt 1	Attempt 2	Attempt 3	Mean
1.0	3.8	3.9	3.7	3.8
2.0	7.8	7.7	7.7	7.7
3.0	11.2	11.4	11.6	11.4
4.0	12.0	14.9	15.1	13.8
5.0	19.0	18.9	19.1	19.0

There is an anomaly in the results.

Identify the anomaly and explain how the student could have dealt with it.

.....

 [2]

(c) Explain what is meant by a reproducible experiment.

.....
 [1]

- 21 (a) (i) Name the rule which can be used to predict the direction of the force perpendicular to a current-carrying conductor in a magnetic field.

..... [1]

- (ii) A student places four wires of different lengths (**A**, **B**, **C** and **D**) perpendicular to different magnetic fields with different currents flowing.

Look at the table of the results.

Wire	Magnetic flux density (T)	Current (A)	Length (m)
A	0.10	2.5	0.50
B	0.15	2.0	0.75
C	0.20	4.5	0.25
D	0.25	5.0	1.00

Use the results to show that wire **D** experiences the highest force.

Show your working.

.....

 [2]

(b) (i) The student decides to build a model transformer.

The transformer is a step-up transformer which doubles the input voltage.

Describe how she could build this step-up transformer in a science laboratory.

.....
.....
.....
.....
..... [4]

(ii) Suggest **one** risk associated with this experiment and how it can be reduced.

.....
..... [2]

(c) Describe how a microphone works.

.....
.....
..... [2]

22 Two ice skaters **A** and **B**, at rest, start together on the ice.

The ice skaters push apart and they move off in opposite directions.

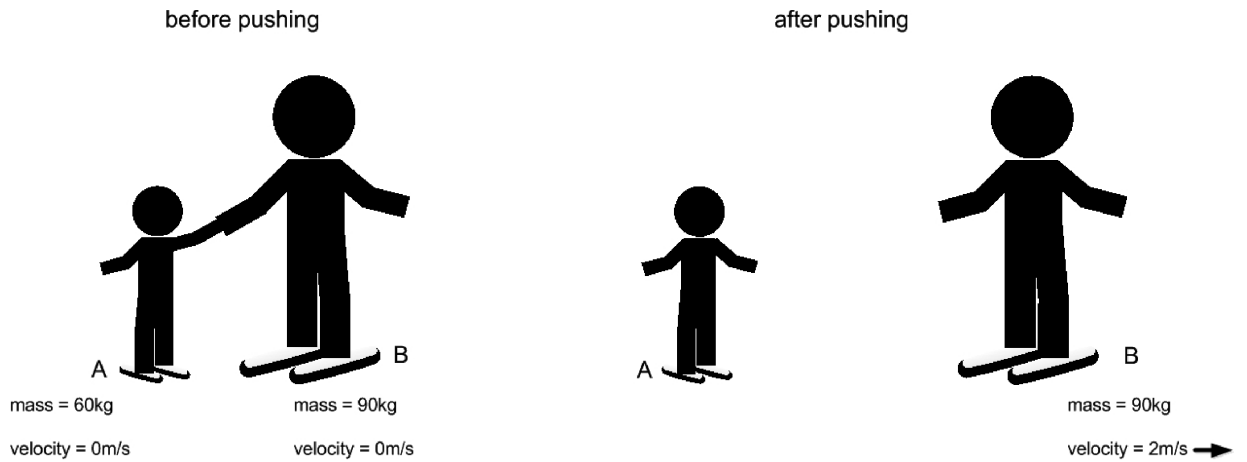

(a) State the law of conservation of momentum.

.....
..... [1]

(b) Calculate the velocity of skater **A** after pushing.

Use the information and your knowledge of momentum to help.

.....
.....
.....
..... [2]

- 24 A free-fall skydiver falls from a plane and reaches terminal velocity after 15 seconds.

Look at the graph of her motion.

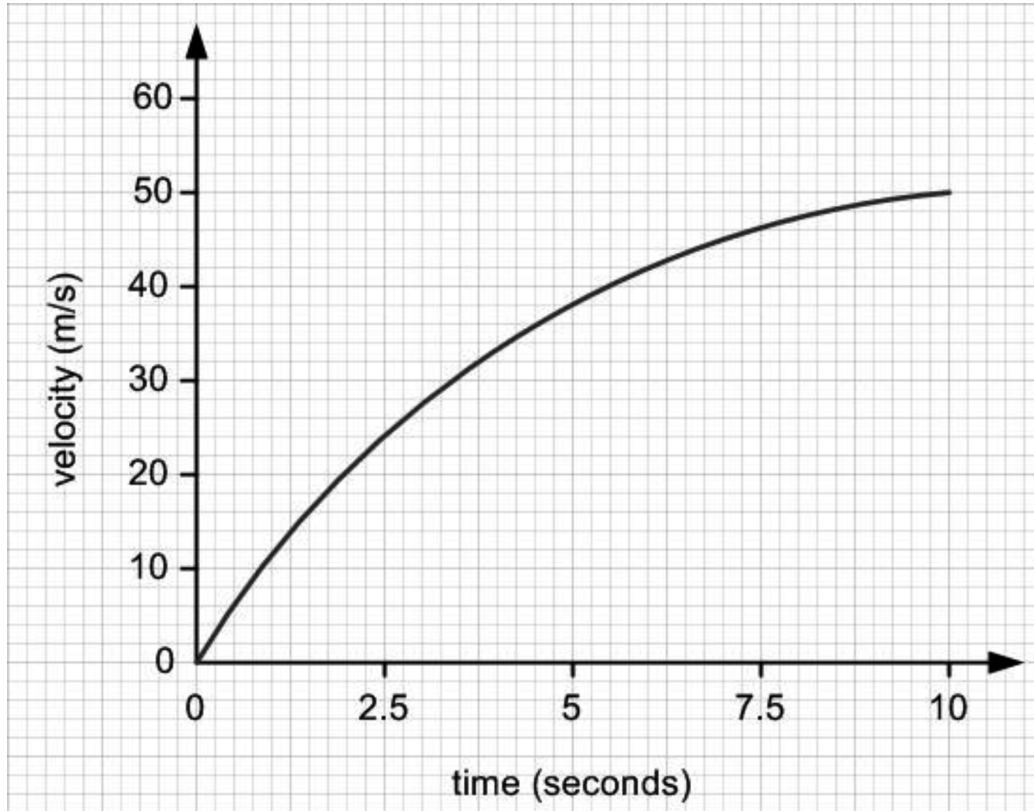

- (a) Use the graph to find the acceleration at 5 seconds.

.....

.....

.....

.....

.....

Answer= m/s² [3]

- (b) Use the graph to find the distance travelled between 0 and 2.5 seconds.

.....

.....

.....

Answer= m [2]

OCR

Oxford Cambridge and RSA

Copyright Information

Image reproduced by permission from George Retseck. www.georgetseck.com

OCR is committed to seeking permission to reproduce all third-party content that it uses in the assessment materials. OCR has attempted to identify and contact all copyright holders whose work is used in this paper. To avoid the issue of disclosure of answer-related information to candidates, all copyright acknowledgements are reproduced in the OCR Copyright Acknowledgements booklet. This is produced for each series of examinations and is freely available to download from our public website (www.ocr.org.uk) after the live examination series.

If OCR has unwittingly failed to correctly acknowledge or clear any third-party content in this assessment material, OCR will be happy to correct its mistake at the earliest possible opportunity.

For queries or further information please contact OCR, The Triangle Building, Shaftesbury Road, Cambridge, CB28EA.

OCR is part of the Cambridge Assessment Group; Cambridge Assessment is the brand name of University of Cambridge Local Examinations Syndicate (UCLES), which is itself a department of the University of Cambridge.